

SAURER.



Be smarter.

Autocard SC7





Saurer pre-spinning is the foundation of the Zinser Ring Spinning and Schlafhorst Open End Systems. The flexible portfolio offers the right solutions for preparation of all kinds of fibres for the subsequent processes. The right combination of blowroom and carding machines ensures excellent fiber utilization and sliver quality for high efficiency and yarn quality in spinning.

E³: Optimising energy, economics and ergonomics, adding intelligence. With our customers' needs always top of mind, E³ forms the basis of our design philosophy. Our passion for textile machinery drives us to manufacture innovative products that add value to our clients' businesses.

Contents

6

The 2nd generation

8

Blow-carding process

10

Sustainable carding

11

Intelligentization +
Digitalisation + Automation

12

High sliver quality

14

High efficiency

15

Technical data

16

Autocard SC7 – Structure
diagram

18

Senses & Sun

Spotlight Sustainability.

Sustainability has been a focus at Saurer for decades. Saving resources is enormously important to us when developing new machines, technologies and upgrades. Our machines are optimised for the processing of sustainable fibre materials. Benefit from these features in the future when you use sustainable fibres to give textiles a second life.



Our development philosophy

Through cutting-edge research and development, we boost our clients' profitability by improving our products' flexibility, increasing output and saving on raw material. Increasingly, our machines are also becoming smarter, reducing the need for human involvement, which allows our customers to save on cost.

With the transformation of the textile industry for the Circular Economy, the processing of sustainable fibres is another important focus point in our developments.

Economics

- Up to 20% more productivity
- up to 4.2m² carding area
- Space Saving and less energy cost
- less maintenance cost in production
- reduced workload



Carding width
in metre

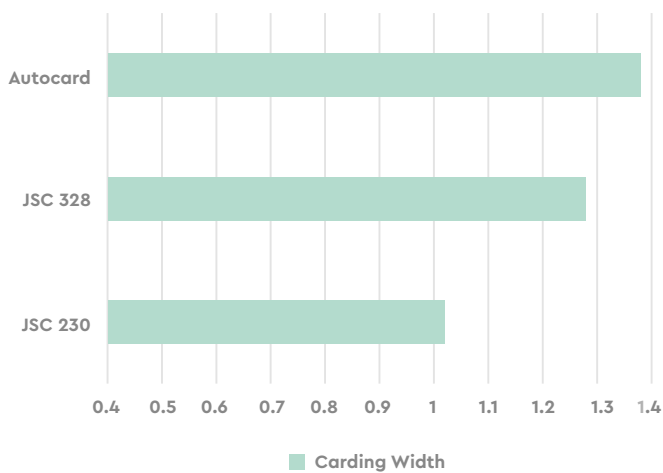

Carding area
in square meter

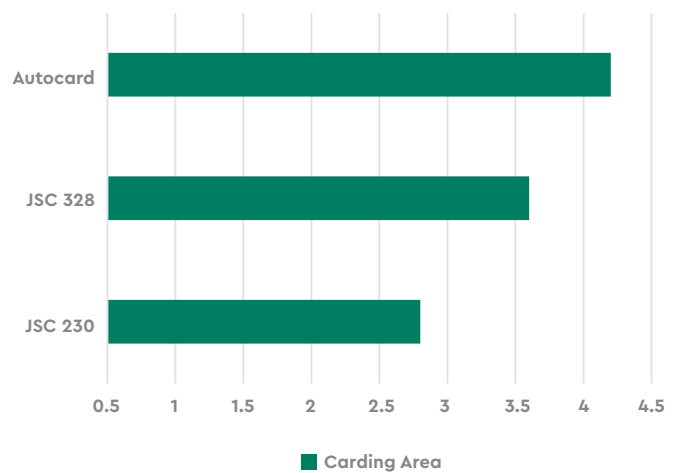

The 2nd generation.





- **More sustainable:** Less energy, higher performance with larger carding area and integrated chute feeder, more productivity, longer cleaning intervals
- **Better automation:** Automatic adjustment of revolving flats gauge, pneumatic auto-piecing up
- **More digital:** Droppings detection and automatic setting, improve the utilization rate of materials and benefit customers' profitability

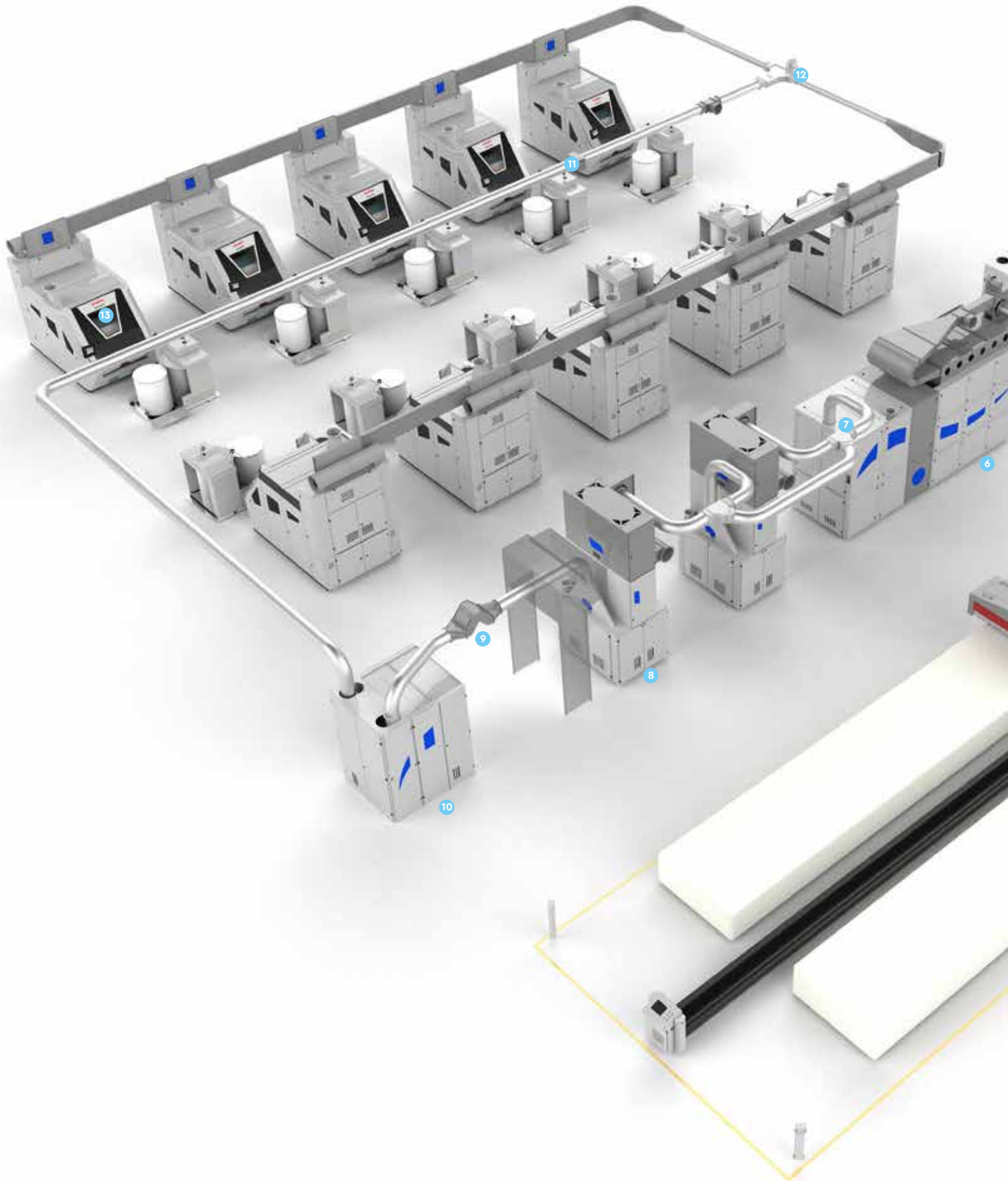

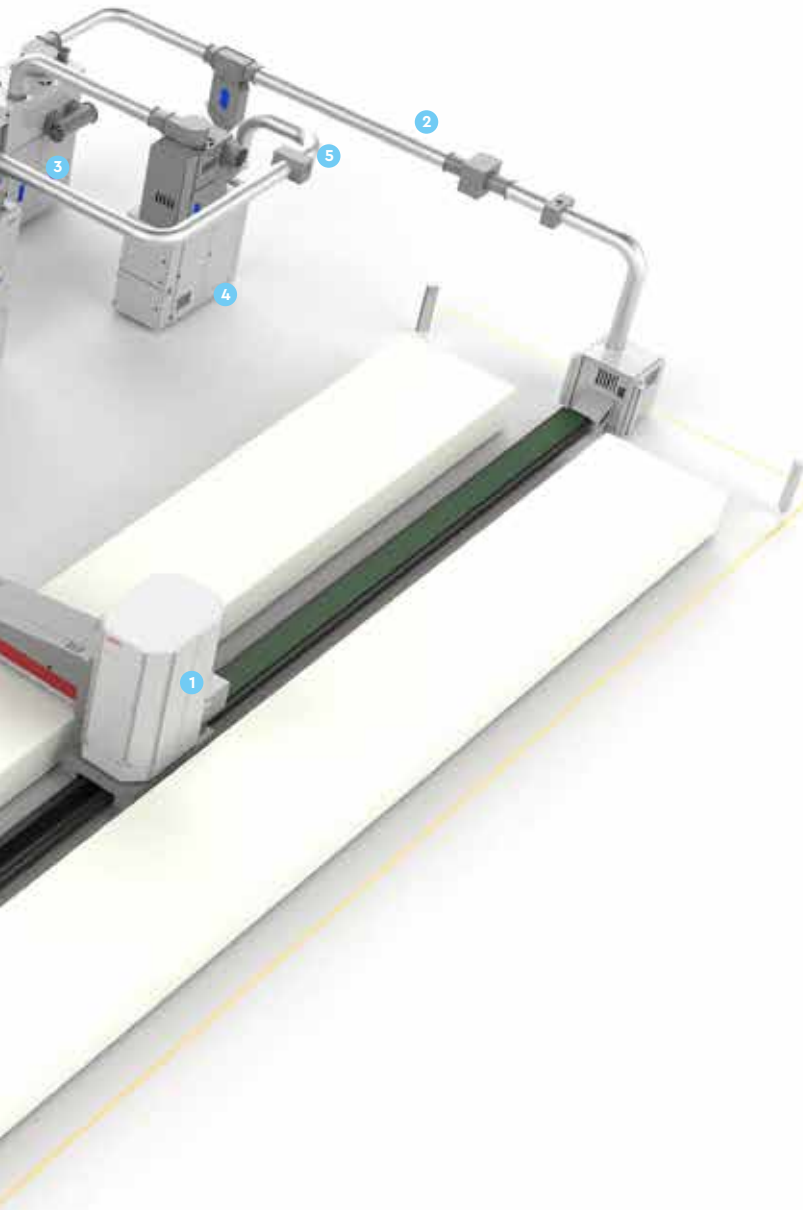

1 JSB 008C Reciprocating Bale Plucker

2 119MT-6000/119MD5
Spark&Metal Dual Separator

3 FA100 Multi-function Air-flow Tower

4 JSB 103 Mono-axial Flow Opener

5 119E Spark Separator

6 JSB 325/JSB 027 Multi-mixer

7 TF29 Three-way Control Valve

8 JSB 318 Fine Opener

9 TF27 Magnet Trap

10 SFA201 Dedusting Machine

11 119E Spark Separator

12 TF80 T Shape Distributor

13 Autocard

**Flexible Blow-carding
process for all material
from cotton to man-
made fibres.**



Sustainable carding

Autocard SC7 is the second generation of Autocard which can create much more value in the fibre preparation chain. Focus on automation, digitization and ergonomics, Autocard SC7 assists yarn mill operators in obtaining more production, higher quality, and less labor.

The right combination of blow room and carding machinery ensures excellent fibre utilisation and sliver quality, thus increasing the efficiency of the spinning process and improving the quality of yarn.

Droppings detection and automatic setting

Droppings detection device has been added to suction hood of licker-in 1st waste collection area to monitor the droppings the carding machine in real-time. Automatic adjustment of fibre drop can ensure maximum fibre utilization and satisfied sliver products.

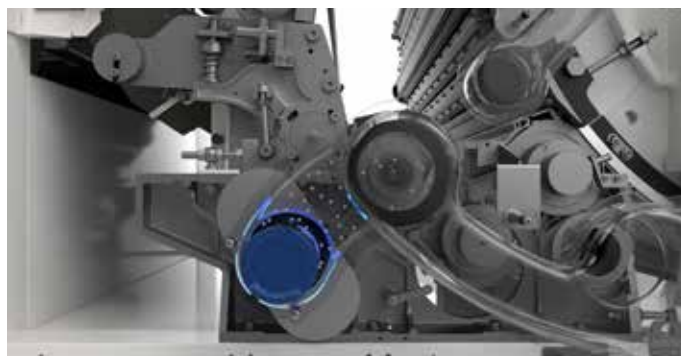



Intelligentization + Digitalisation + Automation

Automatic adjustment of revolving flats gauge

The revolving flats gauge plays a crucial role in controlling the quality of the card web. The optimal gauge value can optimize the reduction of neps and impurities, reduce fiber damage, and also improve the service life of card clothing.

Compared with the overall adjustment of the gauge in the previous generation Autocard, the SC 7 has added an intelligent automatic adjustment function, achieving online fine tuning of the carding web quality. When the spinning factory needs to change batches or process, the work efficiency is greatly improved.

Pneumatic assisted piecing up

High pressure gas forms a spiral airflow through a special spatial structure of the trumpet, and the drafting roller works simultaneously. When the spiral airflow passes through the trumpet, the negative pressure formed sucks in the sliver and passes through the trumpet to form a card sliver.

Compared with traditional carding machines, the process of piecing up is simpler and the time is much shorter. It can reduce the work skill requirements of workers in the carding room and improve production efficiency.



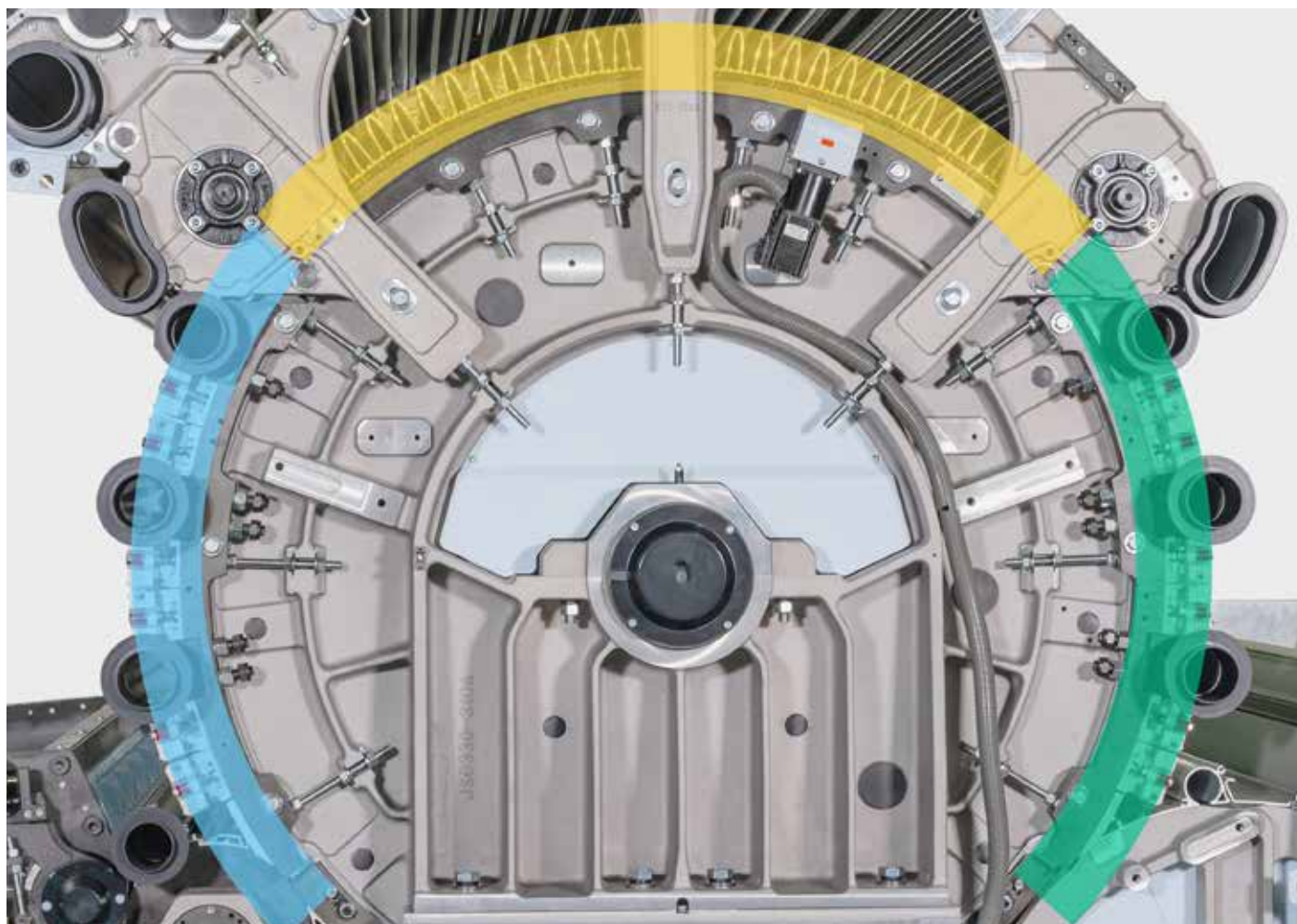

- Front carding 0.9m
- Revolving flats 1.2m
- Rear carding 0.9m

High sliver quality

The longest carding section of 3.0 m

After being opened and cleaned by the lick-in, the fibres are transferred to the working area of the ultra-long cylinder wire with optimized configuration. The fibres get an intensive and gentle pre-carding and mixing, ensuring an even cleaner sliver and higher fibre parallelism. The carding area measures up to 4.2m² and the machine's dimensions match that of the previous generation, meaning that the Autocard produces more output than its predecessor while occupying the same floor space.

Core components

Thanks to higher precision of key components including cylinder, doffer and electric parts, minimum power consumption can be ensured. In addition, servo motors are widely used in Autocard SC7 so that control precision is improved and pulley changing is no longer necessary during technical adjustment.

Each drafting unit is driven independently which means operators can adjust online process conveniently.



Integrated Chute Feeder

The fibre flow fed from the blowroom process pipeline is continuously and evenly transported to a stainless steel channel after being opened by the beater. It will be opened again by the licker-in, which becomes more uniform and loose. The fibres are easy to be carded, thereby ensuring better uniformity of the sliver.

The integrated chute feeder adopts a closed stainless steel channel, greatly improving the uniformity and stability of feedings, reducing the very short fibre and dust in the air. The structural part of the carding machine is easier to clean, and the equipment maintenance cycle time is much longer.

Seamless can change

Can change is carried out during full production without slowing down the speed of sliver delivery. As a result, the fewer changes in speed have less of an impact on sliver quality. In this way, better sliver quality and higher production can be guaranteed.





High efficiency

User-friendly digital functions

The new Saurer HMI, with a combination of PLC and autoleveller, offers various options to control the operation of the machine precisely. Now, more parameters can be displayed and adjusted conveniently on the large touch screen. With a simple touch of the screen, users can set up multiple parameters individually to control the machine, significantly reducing maintenance costs.

Spacious front observation window

The Autocard SC7 features a uniquely designed front transparent window. This transparent window allows operators to easily understand the operating status of the carding machine without having to open the front cover. Whether in daily production or maintenance, this window provides operators with a direct and clear view of the machine's operating conditions.

Technical data

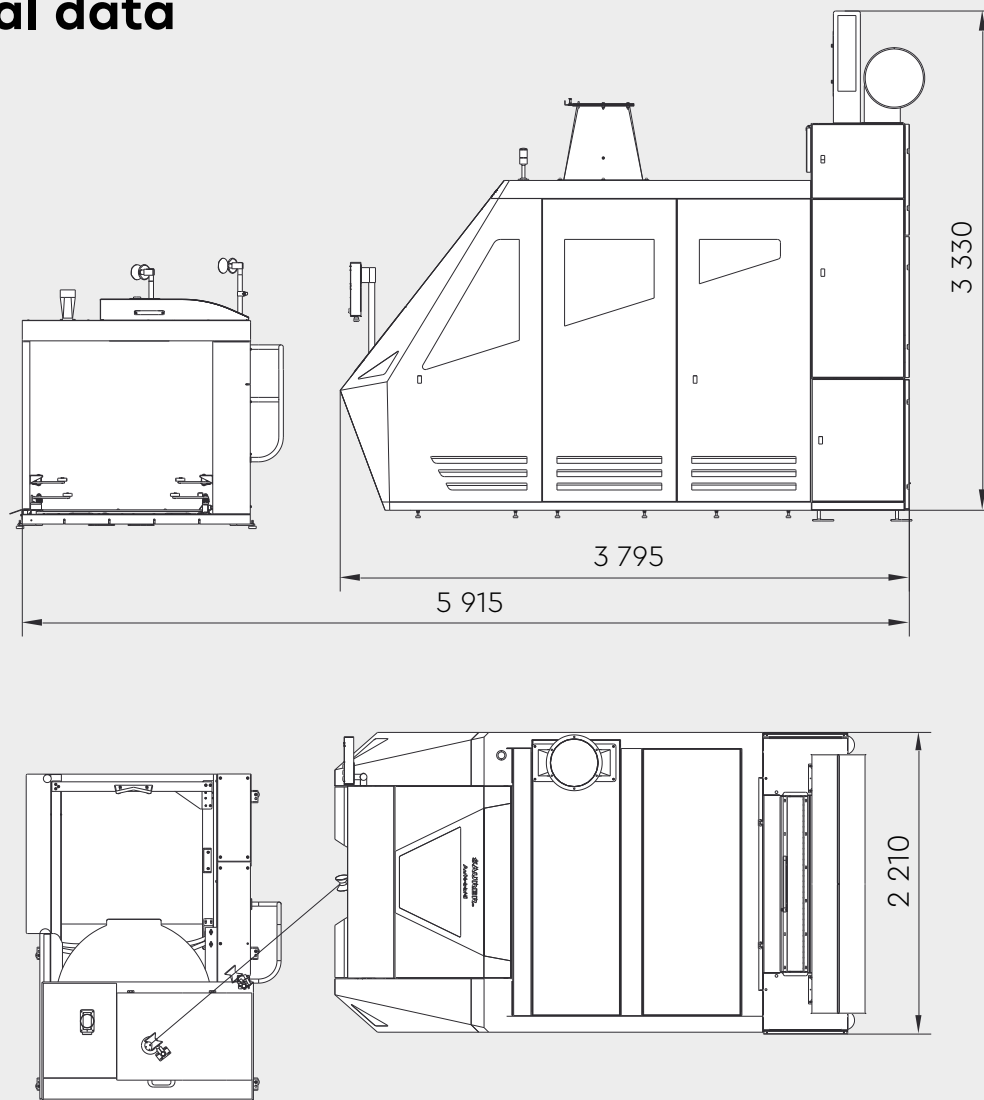

Autocard – Main technical specifications

Type	Autocard SC 7	Autocard SC7 M
Workable fiber	10~76mmcotton and man -made fibers	
Max. Delivery speed (m/min)	480	
Linear weight of card sliver(g/m)	3.5~9	
Cylinder width(mm)	1 380	
Actual max. production(kg/h)	180	
Lap weight (g/m)	340~900	
Lap width(mm)	1 300	
Doffer revolution(r/min)	up to 200	
Licker-in revolution single licker-in (r/min)	1 040/50HZ (Adjustable frequency)	
*First licker-in triple licker-in (r/min)	1 182/50HZ (Adjustable frequency)	
*Second licker-in triple licker-in (r/min)	1 841/50HZ (Adjustable frequency)	
*Third licker-in triple licker-in (r/min)	2 430/50HZ (Adjustable frequency)	
Q'ty of aluminum alloy revolving flats	92 pcs	
Revolving flats speed(mm/min)	V=5.2f (frequency converter)	
Waste extraction air(m ³ /h and pa)	4 800/-850	
Installed power (kW) (including coiler/hopper/MTA)	22.39	21.89
Net weight (kg)	7 300	
Coiler specification(mm)	Diameter (Φ400,Φ450,Φ600,Φ900,Φ1 000,Φ1 200) Height (900,1 000,1 050,1 100,1 150,1 200,1 250,1 300,1 400,1 500)	
Overall diameter (mm)	3 793 × 2 210 × 2 826	

*This is only applicable to carding machines with three licker-ins

Autocard SC7- Structure diagram of triple licker-in

Structure diagram

Chute feeder section

1. Upper chamber
2. Pipe of dust exhaust
3. Fan
4. Feed plate
5. Feed roller
6. Open beater
7. Pressure measuring point
8. Lower cotton channel
9. Return air duct

Carding section

10. Feed roller
11. Feed plate
12. Suction hood of licker-in 1st waste collection area
13. 1st licker-in
14. 2nd licker-in
15. 3rd licker-in
16. Suction hood of licker-in 2nd waste collection area
17. Cover
18. Rear web cleaner
19. Rear stationary flat
20. Suction hood of flat flyer
21. Brush roller
22. Flat brush
23. Flat end brush
24. Revolving flat/working flat
25. Front web cleaner
26. Rear stationary flat
27. Suction hood of doffer
28. Cylinder
29. Doffer
30. Suction hood of three-roller
31. Brush roller of stripping



- 32. Stripping roller
- 33. Web supporting plate
- 34. Squeeze roller
- 35. Apron roller
- 36. Trumpet
- 37. Displacement sensor
- 38. Draft roller
- 39. Suction point of collection
- 40. Touch screen
- 41. Suction point of coiler
- 42. Raster
- 43. Coiler

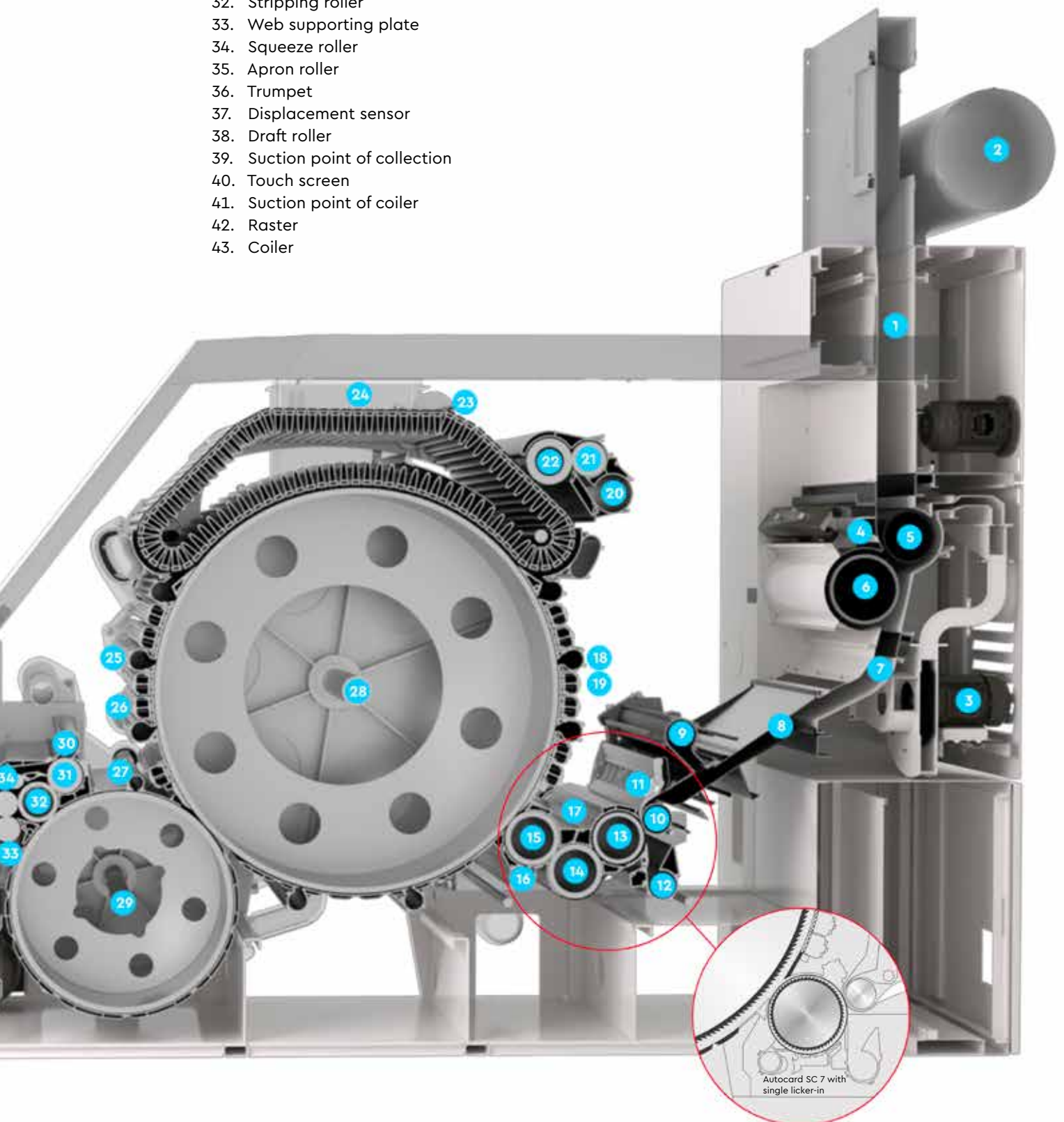

Senses – Sensibly connected.

Visualise your Autocard machine data with Senses.

In Senses you can collect, visualise and analyse the machine data of your Autocard and all other Saurer machines.



Data transparency in pre-spinning

Senses makes the machine data of your Autocard machines transparent. With the help of the individually configurable cockpit, you always have all the data relevant to you in view.



Find out more about Senses.

Simple, fast and secure recipe management*

With Senses, you can easily distribute recipes digitally to your machines. This reduces the setting time at the machine as well as the risk of incorrect entries. In addition, you have an overview of all your machine settings at all times, you can identify deviations and correct them in Senses if necessary.



Find out more about Senses Element Recipe.



Increasing efficiency with off-standard

The off-standard analysis makes it quick and easy to see which cards are not running optimally and you can react accordingly. This increases the productivity of your Autocard machines on the one hand and the sliver of the yarn you produce on the other.



Find out more about our Off-Standard View.

* Some functions are option-dependent

Sun – Service Unlimited.

Keep your pre-spinning competitive with our Life Cycle Partnership.

We offer innovative solutions and services to ensure product quality, machine performance and profitability throughout the machine life cycle. Original parts ensure the full potential of your machine. Tested and proven for decades in spinning mills worldwide.



Updates and Upgrades

Let us increase your productivity and improve the performance of your mill. Keep your machines up to date with our modifications, retrofits and software updates.

Find out about our latest updates & upgrades for your installed machine base.



Preventive maintenance

Preventive maintenance ensures reliable production: you can avoid unplanned machine downtime and keep your mill running at a high level of efficiency.

Find out more about our preventive services for your installed machine base.



Secos – more than just your e-shop

In Secos you can order your original parts online and find all your machine documentation.

Find out more about our Secos e-shop & register now.
secos.saurer.com



Saurer Academy

Learn anywhere, any time with the online media library and book online seminars, presence training at Saurer or your own mill through the Saurer Academy.

Find out more about our Saurer Academy & register now.
academy.saurer.com



Saurer (Changzhou) Textile Machinery Co., Ltd.
558 Huixian Road, Jintan District,
Jiangsu Province
P.R.China 213200
T +86 519 82314836
info.service@saurer.com
saurer.com



Our quality management system complies with the requirements of EN ISO 9001.



Regarding this brochure

Research and development never stand still. This may mean that some statements about the Autocard have been rendered obsolete by technical progress. The illustrations are selected for informative content only. They may contain special equipment which is not included in the standard scope of supply.